

SECTION 3

Masonry Pre-assembled Doors:

Table of Contents

3070 Masonry Door System Description & Dimensions

4070 Masonry Door System Description & Dimensions

6070 Masonry Door System Description & Dimensions

Frame Detail

Wire Anchor Detail

Existing Opening Anchors (EOA) Detail

Installation Guide for Masonry

Installation Guide for Existing Opening

Specifications

**PDL Building Products
3070 Masonry Pre-assembled Door System**

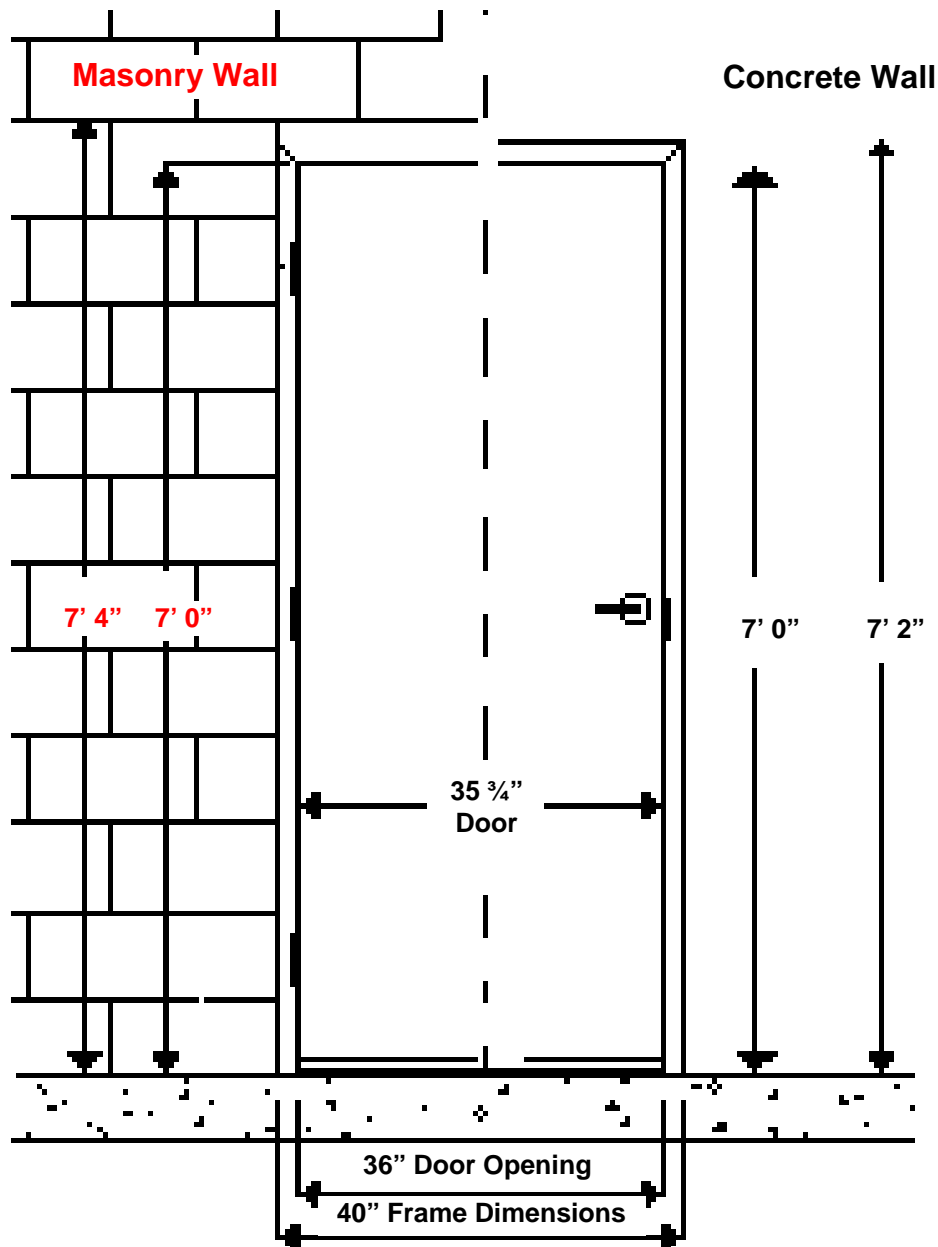

3070 Masonry Pre-assembled Door Includes The Following Components:

1. 20 Gauge, Galvanized, Insulated Door Leaf
2. 5 3/4", 16 Gauge, Galvanized, Insulated, Door Frame (2" or 4" Header)
3. Cylindrical Lever Lock – Grade 2 (26D Finish)
4. (3) Ball-Bearing Hinges – 4 1/2" x 4 1/2" with a Non-Removable Pin (26D Finish)
5. 5 3/4", Aluminum Threshold – ADA Compliant
6. Door Bottom Sweep with Drip Channel
7. Adjustable Full Aluminum Channel Weatherseal
8. (6) Wire Masonry Anchors (3 per side) or (8) Existing Opening Anchors (4 per side)
9. Packaging – Each Door System is Packaged in Heavy Duty Wood Crating
10. All Fasteners and Anchors Included for Complete Installation

**PDL Building Products
4070 Masonry Pre-assembled Door System**

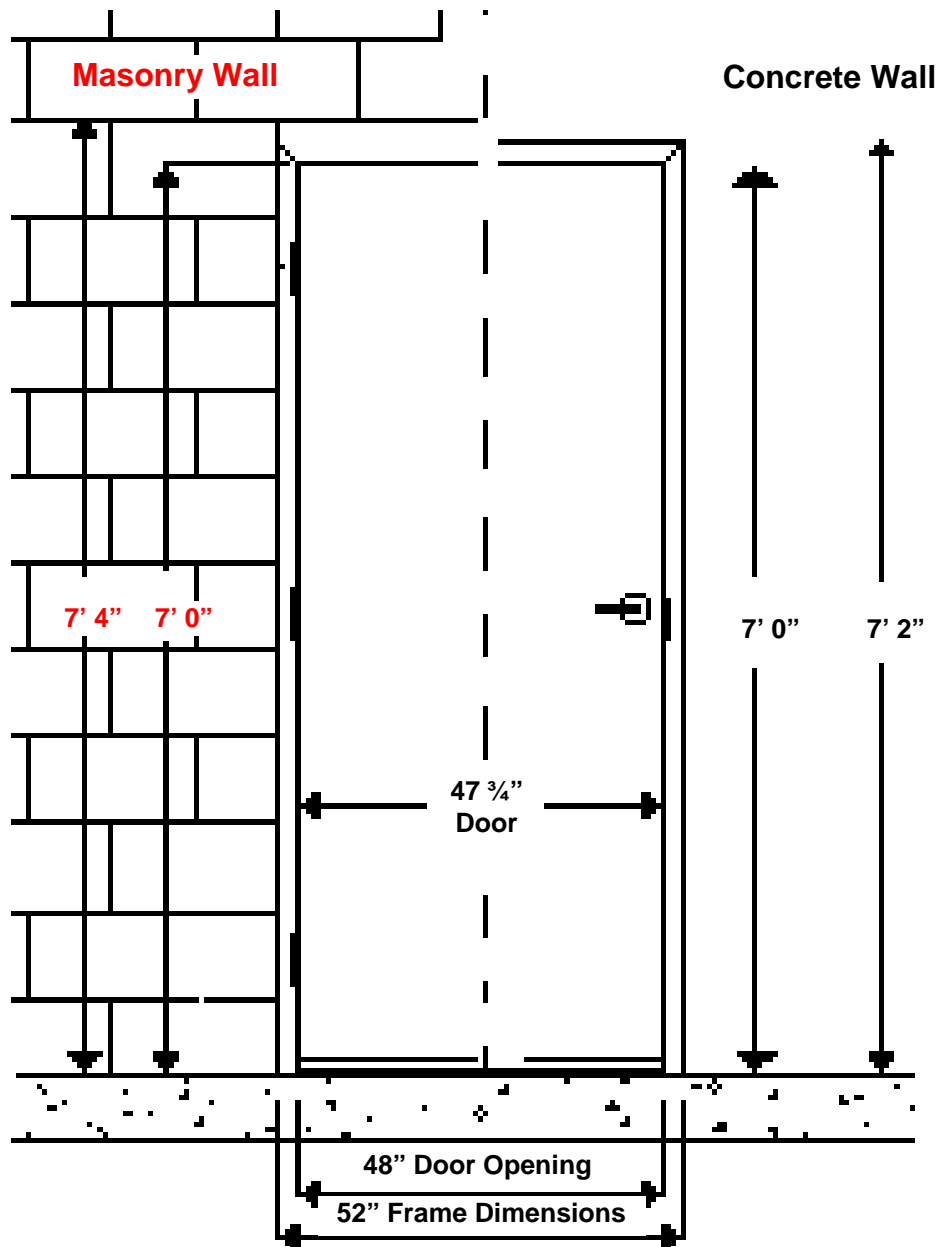

4070 Masonry Pre-assembled Door Includes The Following Components:

1. 18 Gauge, Galvanized, Insulated Door Leaf
2. 5 3/4", 16 Gauge, Galvanized, Insulated, Door Frame (2" or 4" Header)
3. Cylindrical Lever Lock – Grade 2 (26D Finish)
4. (3) Ball-Bearing Hinges – 4 1/2" x 4 1/2" with a Non-Removable Pin (26D Finish)
5. 5 3/4", Aluminum Threshold – ADA Compliant
6. Door Bottom Sweep with Drip Channel
7. Adjustable Full Aluminum Channel Weatherseal
8. (6) Wire Masonry Anchors (3 per side) or (8) Existing Opening Anchors (4 per side)
9. Packaging – Each Door System is Packaged in Heavy Duty Wood Crating
10. All Fasteners and Anchors Included for Complete Installation

**PDL Building Products
6070 Masonry Pre-assembled Door System**

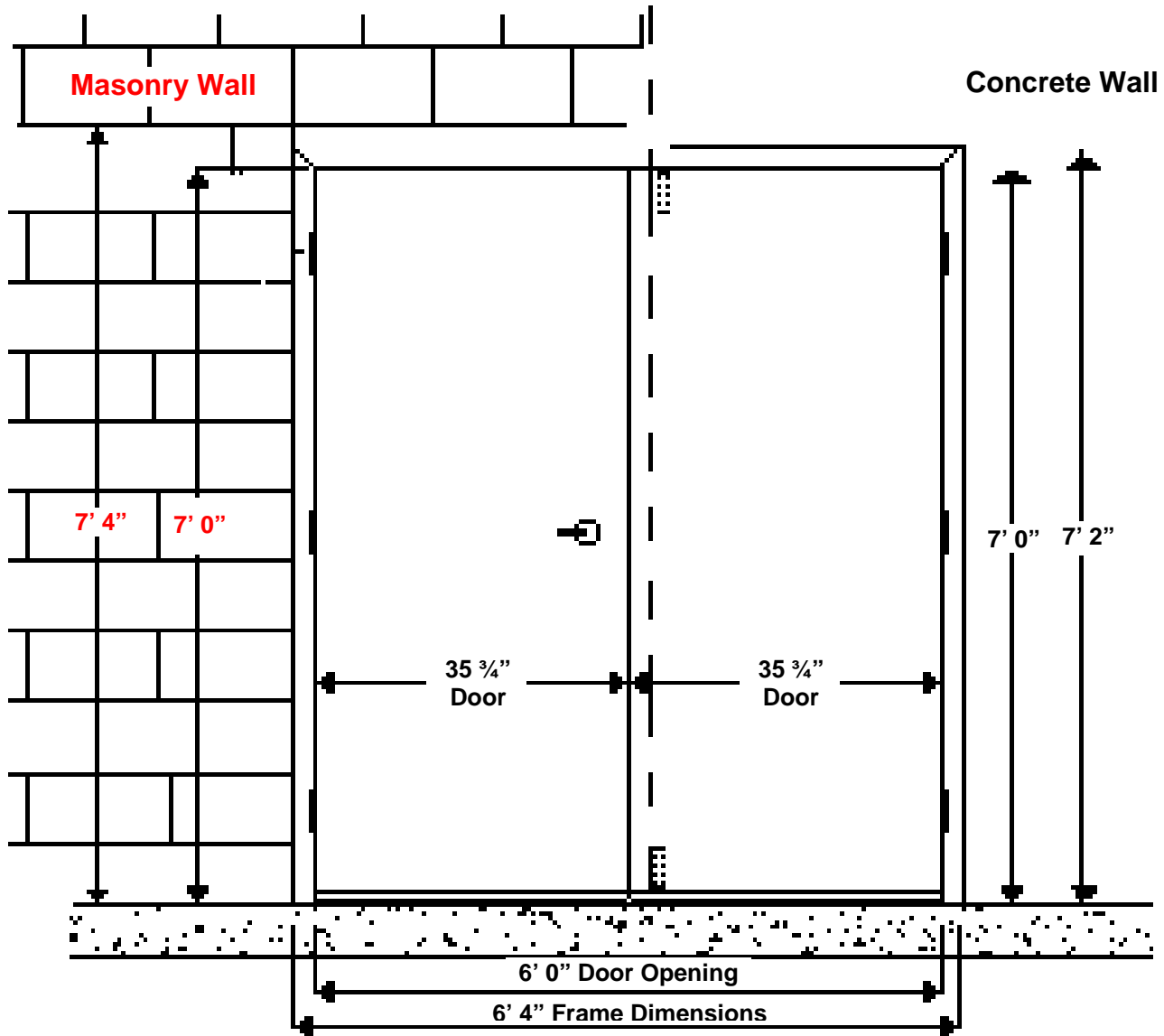

6070 Masonry Pre-assembled Door Includes The Following Components:

1. 20 Gauge, Galvanized, Insulated Door Leaf
2. 5 3/4", 16 Gauge, Galvanized, Insulated, Door Frame (2" or 4" Header)
3. 16 Gauge, Galvanized "Z" Astragal – Attached to the "Inactive" Leaf
4. Cylindrical Lever Lock – Grade 2 (26D Finish) – Installed on the "Active" Leaf Only
5. Surface Bolts (Top and Bottom) – Mounted on "Inactive" Leaf Only (26D Finish)
6. (6) Ball-Bearing Hinges – 4 1/2" x 4 1/2" with a Non-Removable Pin (26D Finish)
7. 5 3/4", Aluminum Threshold – ADA Compliant
8. (2) Door Bottom Sweeps with Drip Channel
9. Adjustable Full Aluminum Channel Weatherseal
10. (6) Wire Masonry Anchors (3 per side) or (8) Existing Opening Anchors (4 per side)
11. Packaging – Each Door System is Packaged in Heavy Duty Wood Crating
12. All Fasteners and Anchors Included for Complete Installation

**Masonry Frame Detail
(16 Gauge, Galvanized)**

Header

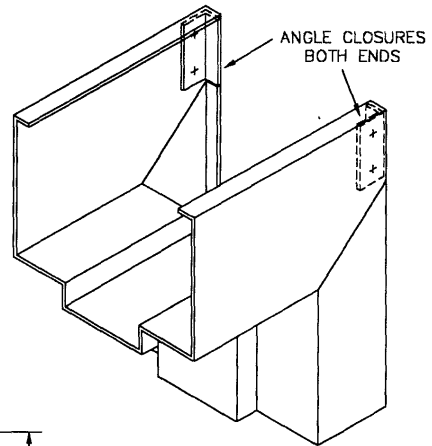
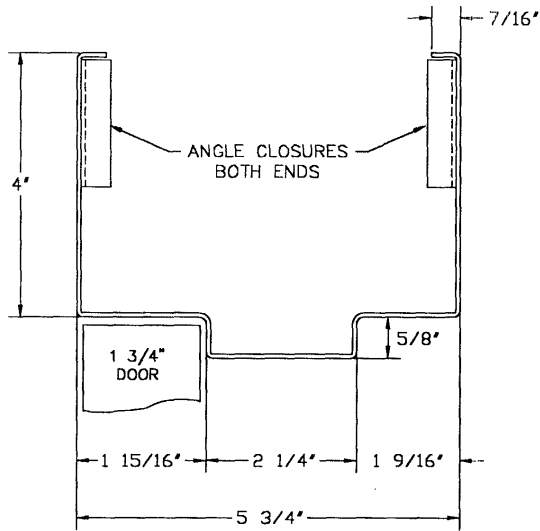

Hinge and Strike Jamb

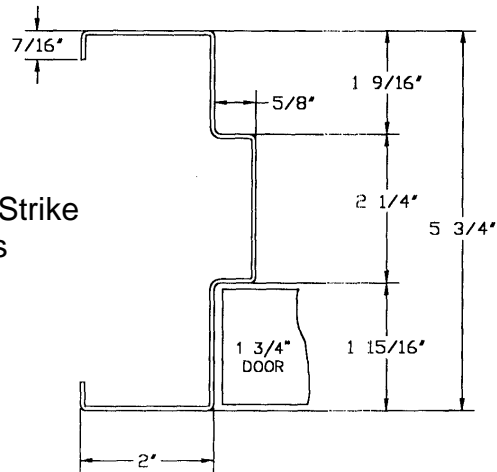

Wire Anchor Detail

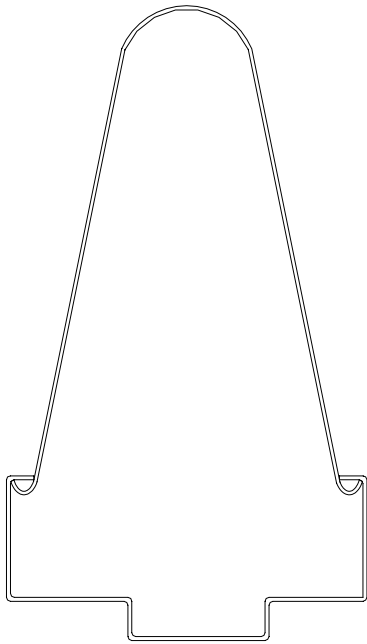

Wire Masonry
Anchor

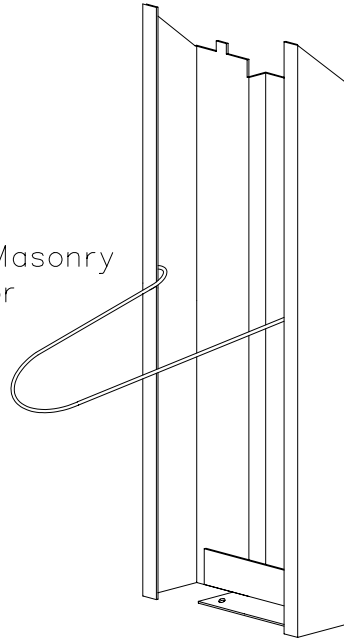

Jamb

Assembly Screws
not Shown

Existing Opening Anchor Detail For Masonry Application

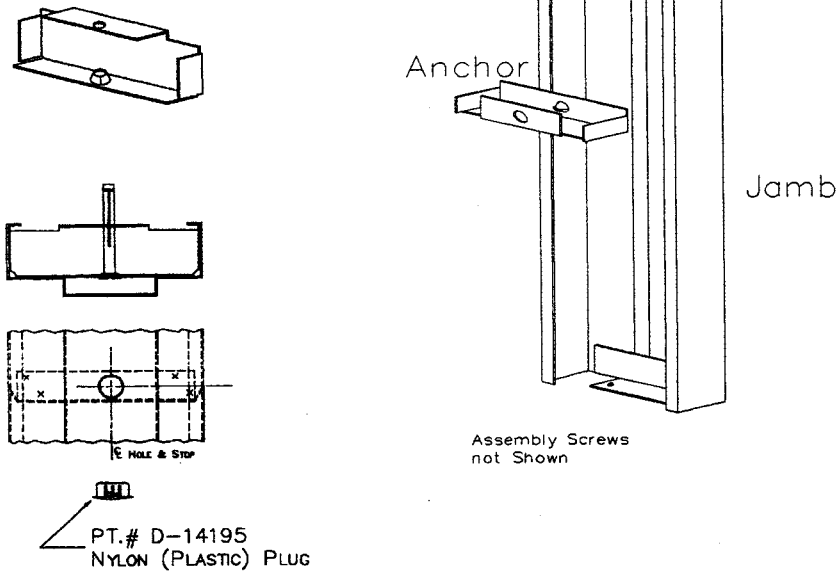

SNAP IN COMPLETED OPENING ANCHOR
USED WITH EXISTING WALL CONDITIONS.
DRILL A 25/32 ϕ HOLE IN SOFFIT
AND ALIGN THE ANCHOR. USE A
DYNA-BOLT OR A BOLT INTO A STEEL
EXPANSION SHIELD. INSTALL A PLASTIC
PLUG TO COVER THE HOLE.

PRE-ASSEMBLED MASONRY DOOR INSTALLATION GUIDE

GENERAL PRE-INSTALLATION NOTE

DO NOT UNLOCK the door until the unit is completely installed. The locked door panel will help aid in keeping the door/frame square during the installation process. Unlocking the door prior to completion of the installation may result in operation problems of the door.

KEYS, ANCHORS, FASTENERS & INSTRUCTIONS for this door are located in the envelope that is attached to the door frame or closer.

This pre-assembled door has been prepared for a MASONRY APPLICATION. Masonry wire anchors have been provided.

INSTALLATION STEPS

- 1. After uncrating the door, position the unit at the desired location. Bracing will be required to steady the unit as the installation progresses.**
- 2. PLUMB AND SQUARE DOOR UNIT. Check the gap between the top of the door panel and header. There MUST be an even reveal.**
3. Six masonry wire anchors were provided with the unit (three per side). Position the anchors into the door frame so that they are approximately in line with the door hinges. As the blocks are being mortared, the wire anchors are to be sandwiched between the blocks into the mortar. Throughout this process, the unit MUST REMAIN PLUMB & SQUARE.
4. After all wire anchors have been secured, remove screws holding door leaf shut and check for proper operation.
5. Anchor threshold to floor with the (3) anchors provided. Caulk or grout under the threshold.
6. Caulk or grout around the perimeter of the frame to prevent air / water infiltration.

PRE-ASSEMBLED DOOR FOR AN EXISTING OPENING INSTALLATION GUIDE

GENERAL PRE-INSTALLATION NOTE

DO NOT UNLOCK the door until the unit is completely installed. The locked door panel will help aid in keeping the door/frame square during the installation process. Unlocking the door prior to completion of the installation may result in operation problems of the door.

KEYS, ANCHORS, FASTENERS & INSTRUCTIONS for this door are located in the envelope that is attached to the door frame or closer.

This pre-assembled door has been prepared for an EXISTING OPENING APPLICATION. The frame has been prepared with “existing opening anchors.”

INSTALLATION STEPS

- 1. After uncrating the door, position the unit into the existing opening. Shimming will be required to steady the unit as the installation progresses.**
- 2. PLUMB AND SQUARE DOOR UNIT. Check the gap between the top of the door panel and header. There **MUST** be an even reveal.**
3. The frame has been prepared with six “existing opening anchors”. Secure each anchor with the fasteners provided. After all the fasteners have been installed, cover the preps with the vinyl caps that have been provided. Throughout this process, the unit **MUST REMAIN PLUMB & SQUARE**.
4. Remove screws holding door leaf shut and check for proper operation.
5. Anchor threshold to floor with the anchors provided. Caulk or grout under the threshold.
6. Caulk or grout around the perimeter of the frame to prevent air / water infiltration.

PDL Building Products Pre-assembled Door Specifications

Door Panel

CONSTRUCTION—Standard door panels will be a flush 1-3/4” leaf with each face formed of 20 or 18 gauge steel to present a completely smooth and unbroken surface on faces of door. Visible seams permitted at door edges. With 16 gauge steel channels forming the top and bottom end closures, the face panels shall be securely projection welded around their entire perimeters. Welding shall occur approximately every 2” on center.

Door panels and end closures shall be manufactured of hot dip material in the 0.6 ounce (A60) coating class conforming to ASTM designations A924 and A653. The material shall be treated in the mill to insure superior prime and paint adhesion.

The panels shall be securely bonded by a thermosetting adhesive to an odorless, rigid foam (nominal 1lb. density) that is resistant to vermin, fungus, bacteria, moisture, mildew and rot.

HARDWARE PREPARATIONS—Lockset locations are in accordance with ANSI/DHI A115.1 (mortise) and A115.2 (bored). The lockset reinforcement shall be 14 gauge.

Hinge mortises shall be reinforced with 10 gauge steel welded in place and tapped for 1 ½ pairs of 4 ½” x 4 ½” template hinges. Mortises shall extend the full width of hinge stile and filler plates shall be provided to permit installation of hinges for right or left hand swing, as specified. The 4 ½” preparation shall accept both regular and heavyweight hinges.

All door panels shall be prepared with a 12 gauge closer reinforcement, which will accept most regular and parallel arm applications. When called for on drawings, or otherwise specified, doors shall be prepared with 14 gauge reinforcements for panic devices and push-pull plates.

Door Frame

CONSTRUCTION—Frames shall be formed of 16 gauge steel. Headers and jambs shall have self-aligning slots and tabs for secure locking of the assembly. Headers to be equipped at each joint with 18 gauge channel-shaped reinforcements. All corners shall present neat butt joints. All stop heights are 5/8”. All frame returns are 7/16”.

All frame members shall be manufactured of hot dip material in the 0.6-ounce (A60) coating class conforming to ASTM A924 and A653. The material shall be treated in the mill to insure superior prime and paint adhesion.

HARDWARE PREPARATIONS—Hinge jambs shall be mortised and reinforced with 10 gauge steel welded in place and tapped for 1 ½ pairs of 4 ½” x 4 ½” template hinges. Hinge reinforcements shall be covered with a welded-in steel plaster guard. Strike jambs shall be mortised and reinforced to receive an ANSI/DHI A115.1 strike (4 7/8” Universal) or optional 2 ¾” strike. Strike jambs shall be prepared to receive three mutes.

Painted Finish

The door panels and frames shall be chemically cleaned and treated with a Bonderite chemical. They are then given a heavy coat of electrostatic – applied finish paint that is baked on. The finish paint shall be a durable formulation, providing good resistance to both mar and abrasion tests. Weather and chemical resistance shall be a property of the finish. The finish is in accordance with the ANSI/SDI Standard A224.1

Subframing (if required for installation)

The subframing creates a framed opening and consists of two galvanized steel 16 gauge C-channels that matches the girt depth for the building. They shall be factory installed and can be prepared to meet most any application (curbs, wainscot). For masonry applications, wire anchors will be provided in lieu of the subframing, or in the case of finished openings, the door frames can be prepared with existing opening anchors.

Standard Hardware & Components

The **THRESHOLD** is factory installed, is 5 ¾” wide (matches frame depth) and is an extruded aluminum. It is saddle shaped not exceeding ½” in height which meets ADA requirements.

The **HINGES** are factory installed and shall be 1 ½ pair, 4 ½” x 4 ½”, five knuckle, two ball bearings, with a non-rising removable pin. They are a template standard weight with a US26D (Satin Chrome) finish.

The **LOCKSET** is factory installed and shall be a heavy duty commercial Grade 2 cylindrical lever with a US26D (Satin Chrome) finish having a 2 ¾” backset. The lockset complies with ANSI A156.2, Series 4000, Grade 2. The function on the lockset is an entrance function (Function #116, ANSI #F81).

The **WEATHERSEAL** is factory installed onto the two jambs and header. It is adjustable and is composed of an extruded aluminum with an extra large Qlon Kurf bulb.

The DOOR SWEEP is factory installed and is composed of an extruded aluminum with a heavy-duty vinyl insert. It is also adjustable and incorporates a drip cap that weeps water away from the threshold.

The SUBFRAME CLIPS are factory installed, adjustable and are composed of 12 gauge galvanized steel. There are two per door.

All of the FASTENERS required for the installation of the pre-assembled door are included in the standard package. The fasteners included are (4) ½" x 2 ¼" hex head sleeve anchors, (3) ¼" x 2" flat head sleeve anchors and (18) #10 x 1" hex head tek screws.

Packaging

The entire door system is packaged in a heavy-duty wooden crate that has been adapted for forklift handling. A bubble packet on the door includes instructions on the lockset and closer (if applicable), all the fasteners required for installation, keys for the lockset and three hinge shims.

Conformance Standards

- ❖ The galvanized doors and frames comply with ASTM A924 general requirements for steel sheet metallic coated by the hot-dip process (formally ASTM A525).
- ❖ Lockset preparation on door leafs shall be manufactured in accordance with ANSI/DHI A115.1 (mortise) and A115.2 (bored).
- ❖ The strike edge of all door leafs shall be prepared for ANSI/DHI A115.1 strike (4 7/8" Universal).
- ❖ The strike jambs shall be mortised and reinforced to receive an ANSI/DHI A115.1 strike (4 7/8" Universal).